

Chapter 26 Examples : DC Circuits

Key concepts:

- **Internal resistance** : battery consists of some idealized source of voltage (called the electromotive force, or EMF, which uses the symbol ξ) and an effective internal resistance r . The actual voltage produced by the battery (called the ‘terminal voltage’) will be $V_{ba} = \xi - Ir$ (which therefore varies as the current in the circuit changes).
- **Resistors in series** : $R_{eq} = \Sigma R_i$
- **Resistors in parallel** : $\frac{1}{R_{eq}} = \Sigma \frac{1}{R_i}$
- **Kirchhoff’s Rules**
 - **NODE or JUNCTION RULE**: at any junction point, the sum of all currents entering the junction must equal the sum of all the currents leaving the junction
 - **LOOP RULE**: the sum of the changes in potential around any closed loop of a circuit must be zero. (Be careful with signs: the voltage will **DROP** across a resistor in the direction the current is flowing, so if your ‘walk’ is in the same direction as the current, ΔV will be negative, **BUT** if your walk takes you across the resistor in the opposite direction the current is flowing, ΔV will be positive.)
- **RC Circuits** : simple circuit with a voltage source ξ , a resistor R and a capacitor C , all in series. Charging: $Q = C\xi(1 - e^{-t/\tau})$ $V_C = \xi(1 - e^{-t/\tau})$ $I = \frac{\xi}{R}e^{-t/\tau}$ where $\tau = RC$
- Discharging a capacitor through a resistance: $Q = Q_0e^{-t/\tau}$ $I = I_0e^{-t/\tau}$ $V_C = Q/C = V_0e^{-t/\tau}$

Older Stuff still used here

- Ohm’s Law: $V = IR$ (voltage will drop in the direction current flows)
- Capacitor: $Q = CV$ (positive charge on the higher voltage ‘side’)
- Power: $P = VI = I^2R = V^2/R$ (V here would be the voltage change just across this single element)

Wire Resistance (and why we usually ignore it)

Let's compare a 'pure' circuit consisting of an idealized battery and a resistor, to two other cases. First, we'll include the internal resistance of the battery, then we'll also include the resistance of the wires themselves.

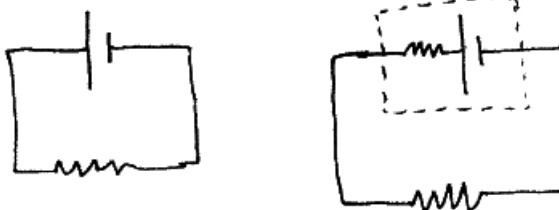

Case 1 : Suppose we have an idealized 12 V battery connected across a 10 Ω resistor. How much current will flow and how much power is this circuit putting out (and where)? The voltage across the resistor is the full 12 volts, so we can determine the current flowing through it: $V = IR$ so here (12 volts) = (I)(10 Ω) or $I = 1.2$ amps. The resistor then is removing energy from the battery (turning it into heat) at a rate of $P = I^2R = (1.2)^2(10) = 14.4$ watts.

Case 2 : Assume the battery has an internal resistance of 0.5 Ω (essentially the figure on the right), but still has an EMF of 12 volts. How much current is flowing now? We have two resistors in series now, which is an equivalent resistor of $R_{eq} = \Sigma R_i = (10 \Omega) + (0.5 \Omega) = 10.5 \Omega$. The current flowing now will be $I = V/R = (12 \text{ volts})/(10.5 \Omega) = 1.143$ amps (slightly less than the 1.2 A we had before).

How much power is being expended? $P = I^2R$ so the internal resistor is expending $P = (1.143)^2(0.5) = 0.65$ W and the 10 Ω load is expending $P = (1.143)^2(10) = 13.06$ W, which is about 9 percent less than before. Accounting for the internal resistance of the battery affected the solution significantly.

Case 3 : Let's add in the actual resistance of the wire itself now. In some earlier examples, we found that the resistance of typical house and circuit wiring is very small - a fraction of an ohm over tens of meters. So let's assume the wire here has a resistance of 0.01 Ω . Now in effect we have three resistors in series: the internal resistance of the battery, the 'real' resistor at the bottom of the circuit, and the wire's resistance. These are still in series, so the equivalent resistance of this circuit is $R_{eq} = \Sigma R_i = 10 + 0.5 + 0.01 = 10.51 \Omega$. The current flowing now will be $I = V/R = (12 \text{ volts})/(10.51 \Omega) = 1.142$ amps (a further but very slight reduction).

Where is the power going now?

The power expended by the internal resistor will be $P = I^2R = (1.142)^2(0.5) = 0.65$ W. The 10 Ω resistor is expending power of $P = I^2R = (1.142)^2(10) = 13.04$ W (nearly the same as the previous case where we accounted for the internal battery resistance but ignored the wire resistance), and the wire itself will be expending power at a rate of $P = I^2R = (1.142)^2(0.01) = 0.013$ W.

Summary : accounting for the internal resistance of the battery made reasonably significant changes to the current flowing and the power being expended by the load (which could be a light bulb, some machine, a speaker, whatever...). Adding in the much smaller resistance of the wiring itself did further reduce the current and power but was a very small correction.

In typical circuit analysis, we just ignore the additional resistance that the wires themselves are introducing.

Determining Battery Internal Resistance

The potential difference across the terminals of a battery is 8.4 V when there is a current of 1.50 A in the battery from the negative to the positive terminal. When the current is 3.50 A in the reverse direction, the potential difference becomes 9.4 V . (a) What is the internal resistance of the battery? (b) What is the emf of the battery?

In the first case, we have the ‘normal’ flow of electricity through this battery. From the end of the chapter, for this case $V_{ba} = \xi - Ir$. When we force the current to flow the ‘wrong’ way by attaching an external source of emf that is stronger than and reversed from the battery, we have $V_{ba} = -\xi - Ir$ but $V_{ba} = -V_{ba}$ so $-V_{ba} = -\xi - Ir$ or $V_{ba} = \xi + Ir$.

(Think of that as if we’re walking along this part of the circuit and applying Kirchhoff’s loop rules: what is the voltage change across each ‘element’ we run into.)

In the first case: $V_{ba} = \xi - Ir$ leads to $8.4 = \xi - 1.50r$

In the second case, $V_{ba} = \xi + Ir$ leads to $9.4 = \xi + 3.5r$.

This gives us two equations and two unknowns to solve. Rearranging each to solve for ξ , we have: $\xi = 8.4 + 1.5r$ and $\xi = 9.4 - 3.5r$ so $8.4 + 1.5r = 9.4 - 3.5r$. Moving the r terms to the LHS and the constants to the RHS: $1.5r + 3.5r = 9.4 - 8.4$ or $5r = 1$ from which $r = 0.200\ \Omega$.

Substituting this value for r into the first equation: $\xi = 8.4 + 1.5r = 8.4 + 1.5(0.2) = 8.7\text{ V}$.

By measuring the potential across and current through a battery running in these two situations, we can determine its true emf ξ and internal resistance r .

(How can we make the current flow the ‘wrong way’ through a battery? By connecting it to a more powerful voltage source that’s connected with a polarity that’s reversed.)

More Realistic Example

We don’t have to use a second battery and try to force the current to flow the wrong way through the first battery. We can determine the actual EMF and internal resistance of a battery by just connecting different resistors to it and measuring the voltage across the battery (or the attached resistor).

When we connect a battery to a $2\ \Omega$ resistance, we measure that the voltage across the battery reads 12.376 volts . If we use a $10\ \Omega$ resistor instead, we find the voltage reads 12.475 volts . What is the actual EMF ξ and internal resistance r of this battery?

As above, the voltage across the battery is $V_{ba} = \xi - Ir$.

In the case of the $2\ \Omega$ resistor, the current flowing is $V_{ba} = IR$ so $12.376 = (I)(2)$ or $I = 6.188\text{ A}$. $V_{ba} = \xi - Ir$, so $\boxed{12.376 = \xi - 6.188r}$.

With the $10\ \Omega$ resistor, $V_{ba} = IR$ so $12.475 = (I)(10)$ or $I = 1.2475\text{ A}$. $V_{ba} = \xi - Ir$, so $\boxed{12.475 = \xi - 1.2475r}$.

The two boxed equations give us 2 equations and 2 unknowns. Rearranging each to solve for ξ we have $\xi = 12.376 + 6.188r$ and $\xi = 12.475 + 1.2475r$ so setting those equal to one another we find that $r = 0.02\ \Omega$ and using that value for r in either of the boxed equations yields $\xi = 12.50\text{ volts}$.

Resistor network (A)

For the circuit shown in the figure both meters are idealized, the battery has no appreciable internal resistance, and the ammeter reads 2.00 A .

- (a) What does the voltmeter read?
 (b) What is the emf ξ of the battery?

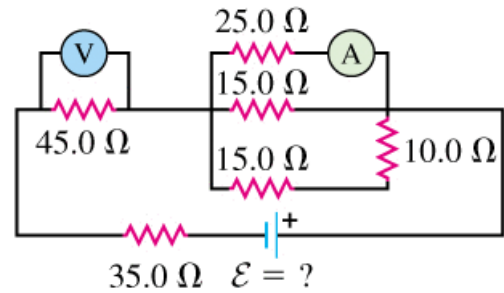

We can solve this (mostly) without resorting to Kirchhoff by nibbling away at it, seeing what we can infer from the lone bit of information we have (the current through the 25Ω resistor).

We only have a single source of voltage here, so the current will flow from the positive terminal of the battery, then counter-clockwise around the circuit, finally reentering the battery at the negative terminal.

We only have a single source of emf here (the battery) so we can start off at least saying that some current will be flowing along the ‘bottom’ of that circuit, heading to the right. This current then splits into three parts, flowing through the little network of resistors, then it recombines and passes through the 45Ω resistor, then the 35Ω resistor, and finally through the battery again.

Let’s start by looking at the cluster of four resistors in the top center of the figure:

Looking at the $25.0\ \Omega$ resistor, we know the current flowing through it is 2.00 A . Thus the voltage drop across this resistor is $V = IR = (25)(2) = 50.0\text{ Volts}$.

This means that the voltage across the middle $15.0\ \Omega$ resistor is also 50 V , implying that $I = V/R = (50)/(15) = 3.333\text{ A}$ is flowing through that resistor. Along the ‘bottom’ of this little resistor network, we have a $15.0\ \Omega$ and $10.0\ \Omega$ resistor in series, which means in effect we have a $25.0\ \Omega$ resistor there, which implies that the current flowing through these two must be $I = V/R = (50)/(25) = 2.00\text{ A}$.

Overall then, some current flows into this network of resistors and splits into three currents (which we now know), and then recombines into the current on the other side. The total current flowing into (and out of) this little cluster of resistors must be $2 + 3.333 + 2 = 7.333\text{ A}$.

This 7.333 A of current now flows through the $45.0\ \Omega$ resistor, at which point a voltage drop of $V = IR = (7.333)(45) = 330.0\text{ Volts}$ occurs. (Answer to part (a).) It then continues on to the 35Ω resistor, at which point a voltage drop of $V = IR = (7.333)(35) = 256.667\text{ volts}$ occurs.

Looking at the entire circuit now, let’s start in the **lower right hand corner** of the circuit and walk around the circuit in a counter-clockwise loop, keeping track of the voltage changes we encounter.

The voltage drops by 50.0 V across the little cluster of 4 resistors (we already knew that from the arguments above), then it drops by 330.0 V across the $45\ \Omega$ resistor, then it drops 256.667 V across the 35Ω resistor, and finally it gains ξ in the battery and we return to where we started. We’ve made a complete loop, so the sum of all these voltage changes must be zero: $-50 - 330 - 256.667 + \xi = 0$ or $\xi = 636.667\text{ V}$ (or rounded to three significant figures, 637 V).

Resistor network (B) : Three resistors having resistances of $R_1 = 1.60\Omega$, $R_2 = 2.40\Omega$ and $R_3 = 4.80\Omega$ are connected in **parallel** to a 28.0 V battery that has negligible internal resistance. Find (a) the equivalent resistance of the combination, (b) the current in each resistor, (c) the total current through the battery, (d) the voltage across each resistor, (e) the power dissipated in each resistor. (f) Which resistor dissipates the most power: the one with the greatest resistance or the least resistance?

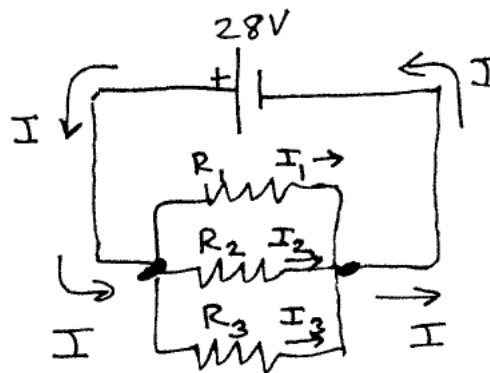

For resistors in parallel, $\frac{1}{R_{eq}} = \frac{1}{R_1} + \frac{1}{R_2} + \frac{1}{R_3}$ so $\frac{1}{R_{eq}} = \frac{1}{1.6\Omega} + \frac{1}{2.4\Omega} + \frac{1}{4.8\Omega}$. We luck out here and can get an exact solution by putting everything over a common denominator: $\frac{1}{R_{eq}} = \frac{3}{4.8\Omega} + \frac{2}{4.8\Omega} + \frac{1}{4.8\Omega} = \frac{6}{4.8\Omega}$. So exactly: $R_{eq} = \frac{4.80\Omega}{6} = 0.800\Omega$.

(Doing it the long way: $\frac{1}{R_{eq}} = \frac{1}{1.6\Omega} + \frac{1}{2.4\Omega} + \frac{1}{4.8\Omega} = 0.6250\Omega^{-1} + 0.4167\Omega^{-1} + 0.2083\Omega^{-1} = 1.250\Omega^{-1}$ so $R_{eq} = 1/(1.250\Omega^{-1}) = 0.800\Omega$.)

The total current flowing will be $V = IR$ or $I = V/R = (28.0\text{ volts})/(0.800\Omega) = 35\text{ A}$, which will also be the current flowing through the battery.

To find the current through each resistor individually: since these are connected in parallel, the voltage drop across each of them is 28 V :

$$I_1 = V/R_1 = (28V)/(1.60\Omega) = 17.5000A$$

$$I_2 = V/R_2 = (28V)/(2.40\Omega) = 11.6667A$$

$$I_3 = V/R_3 = (28V)/(4.80\Omega) = 5.8333A.$$

(Note as a check that the sum of these three is equal to 35.0 A , which is the current we found to have been flowing through the ‘equivalent resistor’ we replaced these three with.)

The power dissipated in each resistor is given by various generic formulas relating the current, resistance, and voltage drop across the resistor: $P = IV$ or $P = I^2R$ or $P = V^2/R$ and the latter is the most convenient to use here since the voltage across each resistor is the identical 28.0 V :

$$P_1 = V^2/R_1 = (28)^2/(1.6) = 490.00\text{ W}$$

$$P_2 = V^2/R_2 = (28)^2/(2.4) = 326.67\text{ W}$$

$$P_3 = V^2/R_3 = (28)^2/(4.8) = 163.33\text{ W}.$$

The total power is the sum of these or 980 W . We can check this by looking at the circuit where we have replaced all the resistors with the single equivalent resistor of 0.8Ω . In that case we have a $28V$ drop across this resistor, meaning that the power being emitted by it is: $P = V^2/R_{eq} = (28)^2/(0.8) = 980\text{ W}$.

The smallest resistor was dissipating the largest fraction of the power. This happens in the case of parallel resistors since the voltage drop across each of them is identical, so in $P = V^2/R$, the lowest resistor will account for the largest power use. (We will find the opposite to be true in the next example where the resistors are in series instead of in parallel.)

Resistor network (C) : Three resistors having resistances of $R_1 = 1.60\Omega$, $R_2 = 2.40\Omega$ and $R_3 = 4.80\Omega$ are connected in **series** to a 28.0 V battery that has negligible internal resistance. Find (a) the equivalent resistance of the combination, (b) the current in each resistor, (c) the total current through the battery, (d) the voltage across each resistor, (e) the power dissipated in each resistor. (f) Which resistor dissipates the most power: the one with the greatest resistance or the least resistance?

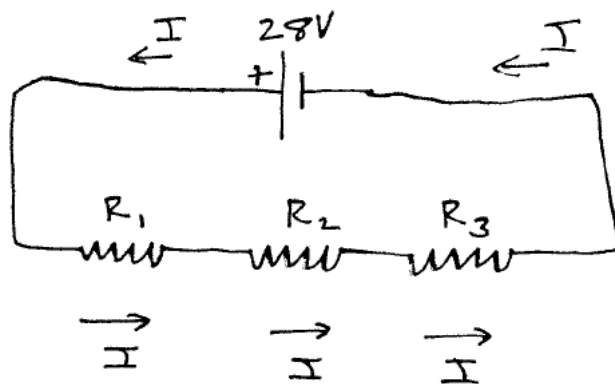

For resistors in series, $R_{eq} = R_1 + R_2 + R_3$ so $R_{eq} = 1.6\Omega + 2.4\Omega + 4.8\Omega = 8.8\Omega$.

That means that we can immediately determine the amount of current flowing in this circuit: $V = IR$ or $I = V/R = (28V)/(8.8\Omega) = 3.182A$. (Which tells us how much current is flowing through the battery at this point.)

This same current is flowing everywhere in the circuit (unlike the parallel case in the previous problem, there are no junctions anywhere here: everything is in a single continuous loop, so there is nowhere for the current to split up). In particular, we can look at each resistor individually. $V = IR$ across each resistor, so we can determine the voltage drop across each resistor:

$$V_1 = IR_1 = (3.182)(1.60) = 5.09 \text{ volts}$$

$$V_2 = IR_2 = (3.182)(2.40) = 7.64 \text{ volts}$$

$$V_3 = IR_3 = (3.182)(4.80) = 15.27 \text{ volts.}$$

The sum of these is 28.0 V as needed: taking a Kirchhoff loop through this circuit, the voltage goes up 28 V at the battery, then drops in total 28.0 V across the three resistors, making the sum of the voltage changes zero around the complete loop, as needed.

The power emitted by each resistor can be found from $P = VI = V^2/R = I^2R$. In this case, the $P = I^2R$ form is the easiest to apply since we know the current is the same in all three resistors:

$$P_1 = I^2R_1 = (3.182)^2(1.6) = 16.20 \text{ W}$$

$$P_2 = I^2R_2 = (3.182)^2(2.4) = 24.30 \text{ W}$$

$$P_3 = I^2R_3 = (3.182)^2(4.8) = 48.60 \text{ W.}$$

The total power used by all three resistors is the sum of these or 89.1 W . We can check this by looking at the power used by the equivalent resistor. In that case we have our 3.182 A current flowing through a single 8.8Ω resistor, so $P = I^2R = (3.182)^2(8.8) = 89.1\text{ W}$. (For yet another check, we have this 3.182 A current passing through the battery which increases the voltage of this current by 28 V so the power being expended by the battery is $P = VI = (28)(3.182) = 89.1\text{ W}$ as well.)

Note that unlike the case of the parallel resistors, when we connect them in series the biggest ‘user’ of power is the largest resistor, instead of the smallest. This is because the CURRENT is the same through each resistor now, and $P = I^2R$ so the power scales up directly with the resistor. (Don’t read too much into these observations, since these cases were simple ones where ALL the resistors were connected either in parallel or series.)

Kirchhoff's Rules : Simple Example 1

Suppose we connect a battery and three resistors as shown in the figure. Determine the current flowing through each resistor and the power each is emitting.

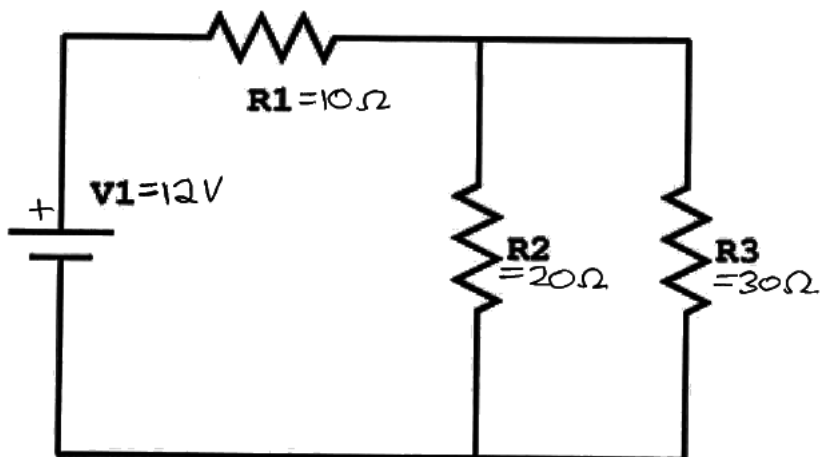

Note: we could do this problem without Kirchoff. The 20Ω and 30Ω resistors are basically in parallel, so they could be replaced with an equivalent resistance of $\frac{1}{R_{eq}} = \frac{1}{20} + \frac{1}{30}$ or $R_{eq} = 12\Omega$. This single resistor is now in **series** with the 10Ω resistor, giving an equivalent resistance of $10 + 12 = 22\Omega$. In the end, we have a 12V battery connected to a 22Ω resistor, giving a current of $V = IR$ or $(12) = (I)(22)$ or $I = 0.54546A$ flowing through the battery.

Let's apply Kirchoff's Laws to this circuit and see if we get the same result.

Process : mark all the **nodes** (places where 2 or more wires are connected to each other), assign currents I in the segments between nodes, identify loops.

Some current will be flowing in the wires in the left half of the circuit. That current splits at node A with some of it flowing to the right and some 'down' through the middle. Those two recombine at node B and continue to the negative terminal of the battery.

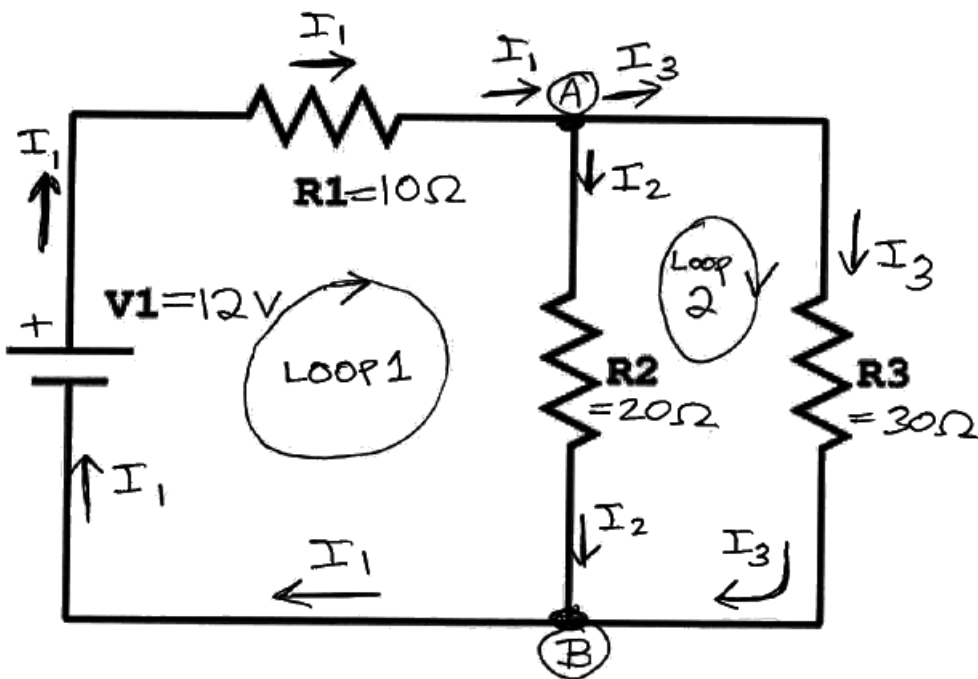

Node rule : at each node, the sum of the currents coming into a node is equal to the sum of the currents leaving that node (or the sum of all the currents, accounting for their directions, will be zero). At node A: $I_1 = I_2 + I_3$, and at node B: $I_2 + I_3 = I_1$. Those are the same equation unfortunately, so we really just get one unique equation from this step: $I_1 = I_2 + I_3$.

Loop rule : start anywhere and make a complete loop, noting the voltage changes as we cross each element in the circuit. The sum of the voltage changes around a complete loop must be zero. (Crossing a resistor, the voltage will drop in the direction the current is flowing, so take great care when ‘walking’ around the loop: if we’re walking in the same direction as the current, that will be a voltage drop but if we’re walking opposite the current flow, the voltage will increase as we ‘step across’ the resistor.)

Loop 1 : clockwise path around the left square, starting in the lower left corner

- we pick up $+12\text{ V}$ when we step across the battery
- $V = IR$ and the voltage drops as current passes through a resistor; as we walk across the $10\ \Omega$ resistor, we’re moving in the direction the current is flowing, so across this element we will have a voltage change of $-10I_1$
- continuing along the loop, current I_2 is passing through the $20\ \Omega$ resistor and we’re walking in the same direction the current is flowing, so we have a voltage change of $-20I_2$ here. The loop now continues along the bottom of the left box and reaches the point where we started, so we’re done.
- That’s a complete loop, so $\Sigma\Delta V = 0$ yields: $+12 - 10I_1 - 20I_2 = 0$

Loop 2 : clockwise path around the right square, starting in the lower right corner

- Walking along the ‘bottom’ of this square loop it’s just wire so we don’t have any voltage change.
- We now walk ‘up’ through R_2 , so there will be a voltage change of $V = IR = (I_2)(20) = 20I_2$ **BUT** we are walking through this resistor in the **opposite direction** the current is flowing. We drew the current ‘vectors’ as if I_2 were flowing **down** so the voltage should drop in that direction. We’re moving across this resistor in the opposite direction through, so from the bottom of the resistor to the top of that resistor, we should see the voltage **rise** by that amount. Here we pick up a voltage change of $+20I_2$
- We now walk along the ‘top’ section of wire in this loop and nothing changes there.
- We now walk along the right side of the loop and we’re walking across R_3 in the same direction as we drew the current I_3 so the voltage here will drop, giving a voltage change from $V = IR$ of $-30I_3$.
- That’s a complete loop, so $\Sigma\Delta V = 0$ yields: $+20I_2 - 30I_3 = 0$

We now have three equations and three unknowns:

- $I_1 = I_2 + I_3$ (from the node rule),
- $+12 - 10I_1 - 20I_2 = 0$ (from the loop on the left)
- $20I_2 - 30I_3 = 0$ (from the loop on the right)

There are many ways of solving these. The third equation basically tells us that $I_2 = 1.5I_3$ so let's use that to **replace** I_2 in the other two equations:

The first equation becomes: $I_1 = (1.5I_3) + I_3$ or just $I_1 = 2.5I_3$. (That's convenient.)

The second equation becomes: $12 - 10I_1 - 20(1.5I_3) = 0$ or $12 - 10I_1 - 30I_3 = 0$

BUT we just found that $I_1 = 2.5I_3$ so we can rewrite that last equation as $12 - 10(2.5I_3) - 30I_3 = 0$ or $12 - 25I_3 - 30I_3 = 0$ or $12 = 55I_3$ or finally $I_3 = 12/55 = 0.21818 \text{ amp}$.

$I_1 = 2.5I_3 = 2.5(0.21818)$ so $I_1 = 0.54546 \text{ amp}$ (matching what we found earlier by not using Kirchoff) and $I_2 = 1.5I_3 = (1.5)(0.21818)$ or finally $I_2 = 0.32727 \text{ amp}$.

Power : We know all the currents flowing now, so let's look at the **power** being dissipated by all the resistances in the circuit and the total power being drained from the battery.

- The 10Ω resistor has $I_1 = 0.54546 \text{ amp}$ flowing through it, representing a power dissipation of $P = I^2R = (0.54546)^2(10) \approx 2.98 \text{ watts}$.
- The 20Ω resistor has a current of $I_2 = 0.32727 \text{ amp}$ flowing through it, so: $P = I^2R = (0.32727)^2(20) \approx 2.14 \text{ watt}$.
- The 30Ω resistor has a current of $I_3 = 0.21818 \text{ amp}$ flowing through it, so: $P = I^2R = (0.21818)^2(30) \approx 1.43 \text{ watt}$.

The total power output would be $\Sigma P = 2.98 + 2.14 + 1.43 = 6.55 \text{ W}$. That's 6.55 J/s and a typical 12V car battery usually stores a few million joules of energy, so it would only take a few days to drain this battery. (Presumably when the car is off, whatever is still pulling power from the battery is doing so at a much lower rate...)

Kirchhoff's Rules : 'Simple' Example 2

Suppose we have two batteries and a single $R = 10\ \Omega$ resistor that we connect as shown in the figure. Each battery has a small amount of internal resistance, denoted by the little $0.1\ \Omega$ resistors next to them. Determine the **currents** everywhere, how much **power** is being dissipated by the center resistor R , and by the internal resistances of each battery, and determine the voltage V_{ba} across resistor R . (Note that the positive terminals of the two batteries are connected together.)

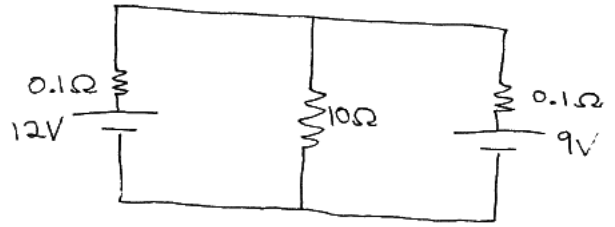

Process : mark all the **nodes** (places where 2 or more wires are connected to each other), assign currents I in the segments between nodes, identify loops.

Some current will be flowing in the wires in the left half of the circuit; some other current will be flowing in the wires in the right half, and some third current will be flowing through the resistor.

Node rule: at each node, the sum of the currents coming into a node is equal to the sum of the currents leaving that node (or the sum of the all the currents, accounting for their directions, will be zero). At node A: $I_1 + I_2 = I_3$, and at node B: $I_3 = I_1 + I_2$. Those are the same equation unfortunately, so we really just get one unique equation from this step: $I_1 + I_2 = I_3$.

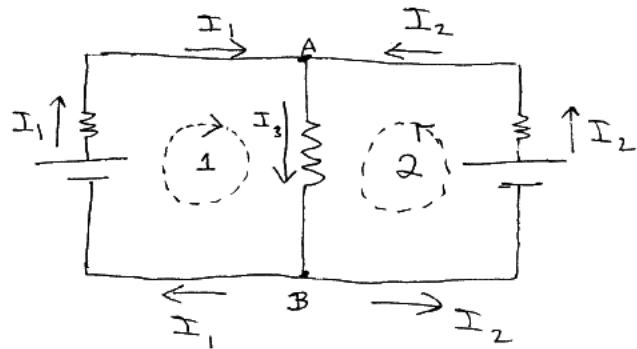

(Note: hard to read but the label on the middle resistor is I_3 .)

Loop rule: start anywhere and make a complete loop, noting the voltage changes as we cross each element in the circuit. The sum of the voltage changes around a complete loop must be zero.

Loop 1 : clockwise path around the left square, starting in the lower left corner

- we pick up $+12\ V$ when we step across the battery
- $V = IR$ and the voltage drops as current passes through a resistor; as we walk across the $0.1\ \Omega$ resistor, we're moving in the direction the current is flowing, so across this element we will have a voltage change of $-0.1I_1$
- continuing along the loop, current I_3 is passing through the $10\ \Omega$ resistor and we're walking in the same direction the current is flowing, so we have a voltage change of $-10I_3$ here.
- That's a complete loop, so $\Sigma\Delta V = 0$ yields: $+12 - 0.1I_1 - 10I_3 = 0$

Loop 2 : counterclockwise path around the right square, starting in the lower right corner

- we pick up $+9\ V$ when we step across the battery
- $V = IR$ and the voltage drops as current passes through a resistor; as we walk across the $0.1\ \Omega$ resistor, we're moving in the direction the current is flowing, so across this element we will have a voltage change of $-0.1I_2$

- continuing along the loop, current I_3 is passing through the $10\ \Omega$ resistor and we're walking in the same direction the current is flowing, so we have a voltage change of $\boxed{-10I_3}$ here.
- That's a complete loop, so $\Sigma\Delta V = 0$ yields: $\boxed{+9 - 0.1I_2 - 10I_3 = 0}$

We now have three equations and three unknowns:

- $I_1 + I_2 = I_3$ (from the node rule),
- $+12 - 0.1I_1 - 10I_3 = 0$ (from the loop on the left)
- $+9 - 0.1I_2 - 10I_3 = 0$ (from the loop on the right)

There are many ways of solving these. Here, the first equation tells us that I_3 is equal to $I_1 + I_2$ so we could make that substitution into the 2nd and 3rd equations, leaving us with two equations and two unknowns:

$$12 - 0.1I_1 - 10(I_1 + I_2) = 0 \text{ or } 10.1I_1 + 10.0I_2 = 12$$

$$9 - 0.1I_2 - 10(I_1 + I_2) = 0 \text{ or } 10I_1 + 10.1I_2 = 9$$

Rearranging the second equation to solve for I_1 : $I_1 = (9 - 10.1I_2)/10.0 = 0.9 - 1.01I_2$ which we can now substitute into the first equation: $10.1(0.9 - 1.01I_2) + 10I_2 = 12$ or $9.09 - 1.0201I_2 + 10I_2 = 12$ or combining terms: $0.201I_2 = -2.91$ and finally $I_2 = -14.48\ \text{amp}$.

We found that $I_1 = 0.9 - 1.01I_2 = 0.9 - 1.01(-14.48) = +15.52\ \text{amp}$.

And finally $I_3 = I_1 + I_2 = (15.52) + (-14.48) = +1.04\ \text{amp}$.

Note the sign that came out for I_2 . That tells us that the current in that part of the circuit is actually flowing the other way, which means it's going through the battery in the 'wrong' direction. Energy is being transferred from the 12V battery into the 9V battery, charging it (but not for long, as we'll see).

Let's look at the **power** being dissipated by all the resistances in the circuit.

The $10\ \Omega$ resistor has $I_3 = 1.04\ \text{amp}$ flowing through it, representing a power dissipation of $P = I^2R = (1.04)^2(10) \approx 11\ \text{watts}$.

The $0.1\ \Omega$ internal resistance of the battery on the left has a current of $I_1 = 15.52\ \text{amp}$ flowing through it, so $P = I^2R = (15.52)^2(0.1) \approx 24\ \text{watt}$.

The $0.1\ \Omega$ internal resistance of the battery on the right has a current of $I_1 = -14.48\ \text{amp}$ flowing through it, so $P = I^2R = (14.48)^2(0.1) \approx 21\ \text{watt}$.

The internal resistors are dumping quite a bit of heat into their respective batteries, which could cause them to dangerously heat up.

Final bit: what is the potential V_{ba} across the resistor? $V = IR$ and we found that $I_3 = 1.04\ \text{amp}$ is flowing from A to B through the resistor, which had a resistance of $10\ \Omega$ so $V = (1.04)(10) = 10.4\ \text{volts}$. The voltage drops in the direction of current flow, so point A is at a higher potential than point B. $V_{ba} = V_a - V_b = +10.4\ \text{volts}$.

Resistor network (D) - Kirchoff's Rules

In the circuit shown in the figure, find (a) the current in resistor R , (b) the resistance R , (c) the unknown emf ξ . (d) If the circuit is broken at point x , what is the current in resistor R ? (NOTE: this is the same circuit as in the previous example, with different numerical values, but here we already know some of the currents...)

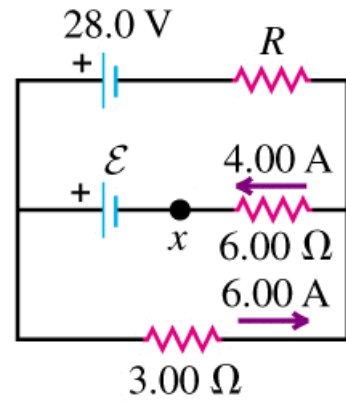

Kirchoff's rules let us convert a circuit into a set of linear equations that we can solve. Anywhere multiple 'wires' connect (called a junction), the sum of all the currents flowing in and out must be zero, and if we make a complete loop around any part of the circuit, the sum of all the voltage changes along that path must add to zero.

The first step then is to mark all the junctions in the circuit. In this case, we only have two: the spots on the left and right where the three wires connect. Now we need to label all the possible currents that could be flowing, remembering that the current can't change unless it comes to a junction. Once we've labelled a current at some point, we can follow that wire along as it passes through resistors and batteries and all along that segment of the circuit the current will be the same value, and in the same direction.

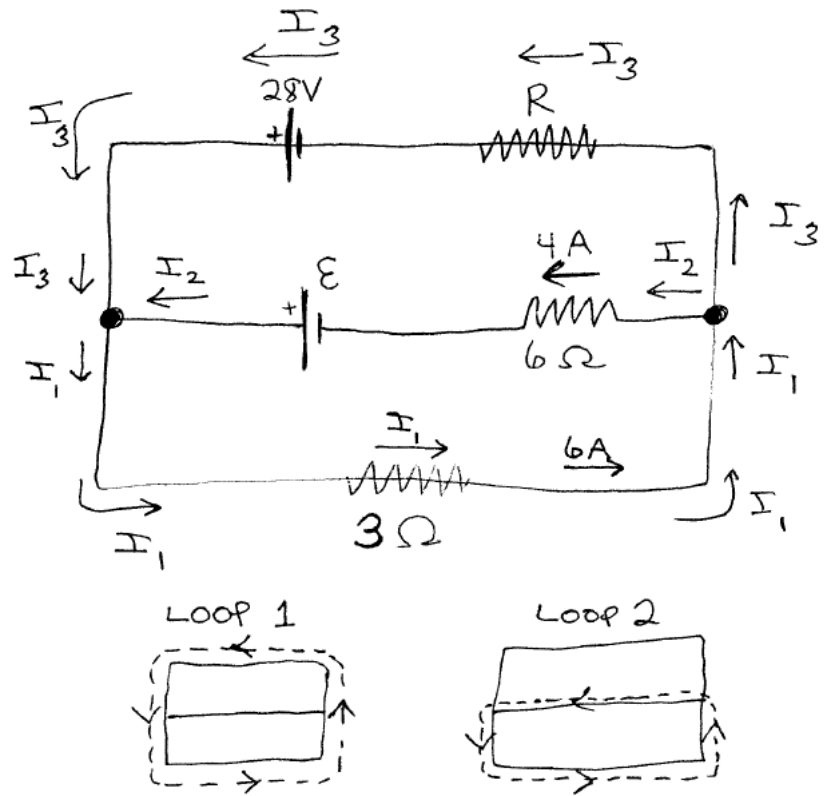

For this particular circuit, we were given that the current in the 'bottom' wire is 6A and is directed to the right, so note that I've labelled all the parts of the circuit where the current must have this same value as I_1 , with arrows denoting the direction the current must be flowing at that point. We were also given that the current on the 'middle' part of this circuit was 4A to the left, so I've called this I_2 and labelled other points along that same segment as such. Finally, there is some unknown current flowing through the top part of this circuit, so I called this I_3 and guessed that it might be travelling counterclockwise. If that 28V battery were the only source of emf in this circuit, the current would definitely be flowing in that direction but since we have multiple batteries, it's possible that the unknown emf along the middle segment of the circuit might be overpowering the known battery and who knows what direction the current might be flowing. It could flow through the known battery in the wrong direction (in which case it is, in effect, charging up that battery).

(Continued...)

The important thing here is to come up with a minimum number of unknowns I_i and choose a direction for each of them, then consistently USE this direction information in the next step. If it turns out you chose incorrectly, all that happens is you end up with a negative value for that current: it's magnitude is still correct, it's just flowing the other way.

JUNCTIONS: at these points, the sum of all the currents must be zero, which is just saying in equation form that the charges don't disappear or pile up. At the junction on the left side of the figure, we have I_1 flowing OUT, and I_2 and I_3 flowing IN, so in equation form we write this as: $-I_1 + I_2 + I_3 = 0$. But we were given that $I_2 = 4$ and $I_1 = 6$ so: $-6 + 4 + I_3 = 0$ or $I_3 = 2$ and we now have all the current values. (In typical Kirchoff problems it isn't this easy but for this case we were given enough information to make this step easy.) **Note** that I_3 came out to be positive, which means we guessed correctly about the it's direction. If you had drawn I_3 going in the other direction, you would have come up with $I_3 = -2$ which is fine, we just have to account for that in later steps.)

LOOPS: We still need to find the values for the unknown resistor R and the unknown emf ξ in this circuit. Let's consider a loop where we walk in a **counterclockwise** direction entirely around the outer part of this circuit (shown as **LOOP 1** at the bottom of the figure above). Starting at the lower left hand corner of the figure, we'll walk in the direction chosen and account for all voltage changes we encounter. The first thing we run into is a 3Ω resistor, through which a current of $6A$ is flowing, to the right: i.e. the same direction we're walking. The voltage drops across a resistor in the direction the current is flowing, so that means that at this point V DROPS by $IR = (6)(3) = 18$ volts. Our voltage change at this point then is $\boxed{-18V}$. We now continue walking around the circuit and nothing happens until we encounter the unknown resistor R , through which is flowing a current of I_3 . If we didn't know either of these quantities, the voltage change at this point would be $-I_3R$. We know that $I_3 = 2A$ though, so the voltage change crossing this resistor will be $\boxed{-2R}$. Now we encounter a battery. The voltage increases inside a battery when we're moving from the 'low side' to the 'high side' of the battery (i.e. from the negative to the positive terminal), and we are moving through this battery in exactly that direction, so here the voltage along our path changes by $\boxed{+28V}$. We continue around this loop and encounter nothing else until we get back to our starting point. Accumulating all the voltage changes then: $\boxed{-18 - 2R + 28 = 0}$ which we can solve to find $10 = 2R$ or $\boxed{R = 5\Omega}$.

To find the unknown ξ , let's use a counterclockwise path through the bottom half of this circuit (labelled **LOOP 2**). Starting again at the lower left hand corner of the circuit, we have a current of $I_1 = 6A$ passing through a $R = 3\Omega$ resistor and we're walking in the same direction as the voltage drop occurs, so this results in a voltage change of $\boxed{-18V}$. We continue around this loop, turning into the middle part of the circuit at the right junction. Now we encounter the 6Ω resistor, through which a $4A$ current is flowing in the same direction we are 'walking', so at this point the voltage **drops** $V = IR = (4)(6) = 24V$, which represents a voltage change of $\boxed{-24V}$. Now we encounter the unknown battery ξ and we're walking through it in the direction that should produce an increase in the voltage level, so the voltage change at this point on our path is $\boxed{+\xi}$. Putting these together, around our entire walk we have: $\boxed{-18 - 24 + \xi = 0}$ or $\boxed{\xi = +42V}$, which also tells us that the polarity of the battery is correctly labelled in the figure.

(Continued on next page.)

NOW WE ARE TOLD that we break the circuit along the middle wire, basically disconnecting the 42V battery from the 6Ω resistor. This changes the circuit into the one shown in this figure. Because of the break, there is NO current flowing through the middle battery or resistor. The current is now flowing just around the remaining outer part of this circuit. Along this path, there are no real junctions anywhere. The 'old' junctions are now pointless, since the current 'flowing' along those little fragments is zero now. Looking at the 'junction' on the left side of the circuit, we have I coming in from above, and the same I continues down. This becomes a fairly trivial circuit now. We have a 28V battery in series with a 5Ω and 3Ω resistor, giving an equivalent resistance of 8Ω. The current flowing in THIS circuit then is $I = V/R = (28)/(8) = 3.5A$

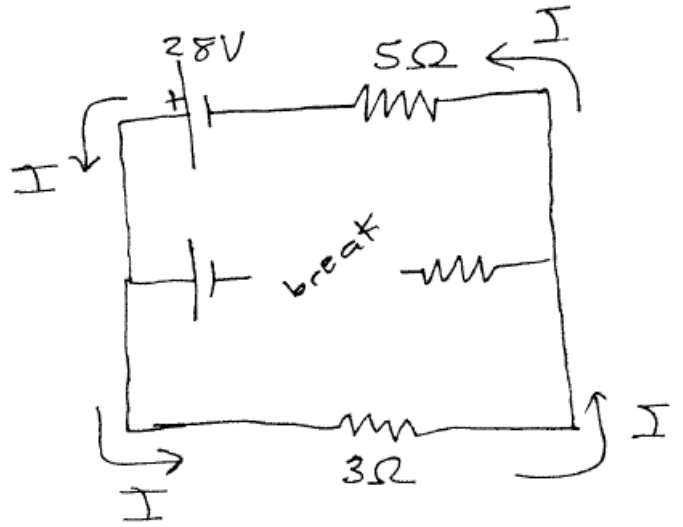

Resistor network (E) - Kirchoff's Rules

In the circuit shown in the figure, both batteries have insignificant internal resistance and the idealized ammeter reads $1.50A$ in the direction shown. Find the emf ξ of the battery. Is the polarity shown in the figure correct? (Again, note that this is the same circuit as the previous examples used but we know different information this time.)

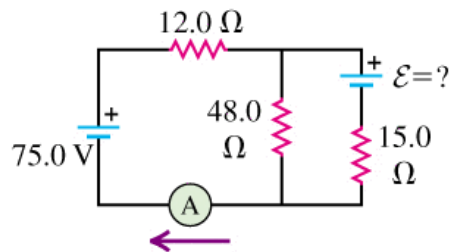

We start by marking the two junctions on the circuit, and then labelling the currents (with 'guessed' directions).

We were given the current at one point, so we'll label that as I_1 . This current starts at the lower junction, continues left through the ammeter, turns and heads through the $75V$ battery, then turns and heads through a 12Ω resistor, at which point it reaches another junction. All along that left 'half' of the circuit, the current has to have the same value I_1 and has to continue in the same direction. Starting at the upper junction, we'll guess that I_2 heads off to the right, turns down through the battery (note it is passing through the battery in the 'wrong' direction but that's fine - we'll take care of that with the proper sign when we start turning the circuit into equations). Then I_2 passes through a 15Ω resistor and turns into the bottom junction. So now we've labelled all parts of the circuit where I_2 exists.

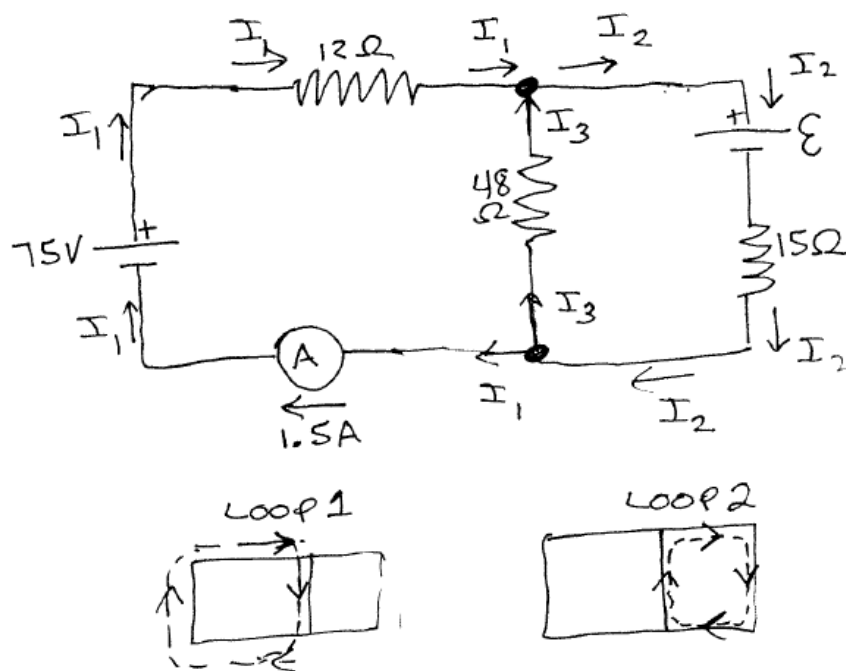

Finally we have the unknown current I_3 passing from junction to junction through the 48Ω resistor. We'll randomly guess that it is going in the direction shown. Again as in the previous problem, what direction you choose DOES NOT MATTER, just be consistent with it when you turn the circuit into equations in the next steps.

JUNCTIONS: at the upper junction, we have I_1 and I_3 coming in, and I_2 going out, so $I_1 + I_3 - I_2 = 0$. We do already know that $I_1 = 1.5A$ so let's write this as $1.5 + I_3 - I_2 = 0$. (The lower junction duplicates this information, so doesn't tell us anything new.)

LOOPS: Let's start by taking a loop around the left half of the circuit, labelled as 'LOOP 1' below the figure. Choosing this loop was not arbitrary: as I looked at all the possible loops in this circuit, this left one involves things we already know plus only a single unknown variable: I_3 . That means that this loop will be enough to directly solve for this unknown. Other choices for loops would have 2 or more unknowns. Still solvable, but I'd end up with a handful of linear equations that I'd need to tinker with, rather than this loop that directly gave a solution. Anyway, starting at the lower left corner

of the circuit, we gain $75V$ passing through the known battery. Next, we encounter the 12Ω resistor. The $I_1 = 1.5A$ current is flowing through this battery in the direction shown, which means the voltage should DROP by $V = IR = (1.5)(12) = 18V$ at this point, giving us a voltage change of $-18V$. Now our Kirchhoff loop walks us from the upper junction to the lower junction. According to our choices for the directions of the various currents, we claimed that I_3 was flowing UP here. That means the voltage should drop by $V = IR = (48)(I_3)$ when I move across the resistor in the direction of the current. But I'm not: my Kirchhoff path is taking me across this resistor in the 'wrong' direction, which means that according to my path, the voltage should RISE by $48I_3$ at this point. The path now continues around to reach where we started with no further resistors or batteries to consider. Our complete equation accumulating all the voltage changes along this loop then is: $+75 - 18 + 48I_3 = 0$ or $48I_3 = 18 - 75 = -57$ or $I_3 = -57/48$ or finally $I_3 = -1.1875A$. (The negative sign means the current is flowing in the opposite direction we thought. That's fine. You could go back and switch the direction of the I_3 in the figure to make it positive in that direction (and also alter any other equations, like the JUNCTION ones, to account for this new direction), or you can just leave things as they are and account for the sign when determining voltage changes later...

From our junction equation, $1.5 + I_3 - I_2 = 0$ or $I_2 = 1.5 + I_3$ and we know $I_3 = -1.1875A$ now, so $I_2 = 1.5 - 1.1875$ or $I_2 = 0.3125A$.

Finally, we can look at the right half of the circuit (shown as LOOP 2 in the figure) to find the unknown ξ . Using our original labels and directions, if we walk clockwise around this loop starting at the lower junction, we first pass through the 48Ω resistor in the same direction the current I_3 was presumed to be flowing, so we have a voltage change of $-48I_3$ here. Next we go through the battery in the wrong direction, giving us a voltage change of $-\xi$. Then we have current I_2 passing through the 15Ω resistor and we're walking in the direction for which the voltage should drop, so we have a voltage change here of $-15I_2$. The sum of all these voltage changes then is: $-48I_3 - \xi - 15I_2 = 0$ so $\xi = -48I_3 - 15I_2 = -48(-1.1875) - 15(0.3125) = +57.0 - 4.6875$ or finally $\xi = +52.3125$. The sign implies that the polarity of the battery was labelled correctly. If we had gotten a negative value here, then the $+$ sign on that battery would have had to have been on the other side.

Resistor network (F) : (Redoing an example I made up on the fly for a lecture and didn't get the currents to add up properly...)

In the circuit shown, assume we have an idealized 48 V battery that is connected to the resistor network shown. The three resistors in parallel all have the same resistance: $R_1 = R_2 = R_3 = 10\Omega$, and $R_4 = 40\Omega$.

Determine the overall current flowing, the voltage drop from A to B, the voltage drop from B to C, the current flowing through each resistor, and the power being emitted by each resistor.

Assume the wires themselves have no resistance. (They will have some, but it will be tiny fractions of an Ohm, so won't significantly affect the results.)

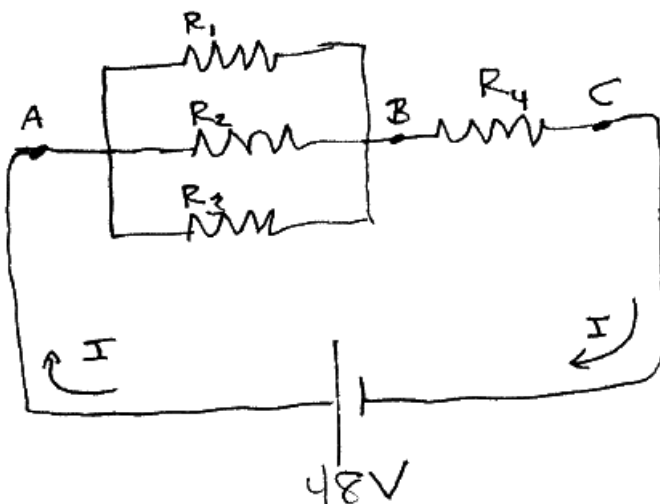

First, let's compute the equivalent resistance here. We have three 10 ohm resistors in **parallel**, so they add inversely: $\frac{1}{R_{eq}} = \sum \frac{1}{R_i}$ so here: $\frac{1}{R_{eq}} = \frac{1}{10} + \frac{1}{10} + \frac{1}{10} = \frac{3}{10}$ so $R_{eq} = 10/3 = 3.3333...\Omega$.

We've replaced the three in parallel with this single 3.333... Ω resistor.

That leaves us with two resistors in **series**, which we can combine using: $R_{eq} = \sum R_i = 3.333... + 40 = 43.333...\Omega$.

Our circuit now consists of the 48 V voltage source flowing through this single equivalent resistance of 43.333... Ω . We can find the current flowing then from $V = IR$ so $I = V/R = 48/43.3333... = 1.1077 A$. (I'm keeping lots of significant figures here to avoid the round-off problem I had in the lecture.)

That's the amount of current that flows through the battery and runs along the wires into the resistor network, then out of it and back into the battery.

Expanding the resistors back out, how much does the voltage drop across resistor 4? $V = IR$ so $V = (1.1077...A)(40\Omega) = 44.3077 volts$. Walking completely around the circuit, we gain 48 volts at the battery, lost some unknown voltage V across the network of three resistors, then lose 44.3077 volts across the 40 ohm resistor, and then we're back where we started so $48 - V - 44.3077 = 0$ or $V = 3.6923... volts$ must be the voltage drop across the little 3-resistor network.

Focusing on that little sub-network, the voltage across each of those three resistors is 3.69 volts so we can compute the current through each of them. $V = IR$ again, so $I_1 = V/R_1$, $I_2 = V/R_2$, etc. Since all these resistors were the same value, $I_1 = I_2 = I_3 = (3.69 volts)/(10 \Omega) = 0.36923... amps$.

The total current flowing through these three resistors will be $0.36923+0.36923+0.36923 = 1.1077 amps$ (identical to the 1.1077 amps flowing into and out of that little sub-network).

How much power is each resistor emitting?

We found that each of the little 10 Ω resistors had 0.36923.. A of current flowing through them, so $P = I^2R = (0.36923...)^2(10) = 1.3633 W$. We found that 1.1077 A was flowing through the 40 Ω resistor, so it is emitting heat at rate of $P = I^2R = (1.1077...)^2(40) = 49.08 W$.

Combining all four resistors, they're emitting a total of $(1.3633)(3) + 49.08 = 53.2 W$.

Looking back, at one point we had combined all the resistors into a single equivalent resistor of $43.333\ \Omega$, through which $1.1077\ A$ of current was flowing, so that gives us a total power output of $P = I^2 R = (1.1077)^2(43.333\ \Omega) = 53.2\ W$ also.

The battery is losing energy at that rate (which probably won't last long...)

Jump-starting a car - Kirchoff's Rules

First, let's look at the normal situation: the car battery connected in series with the starter motor. The battery provides some internal EMF ξ (volts) and also contains an effective internal resistance r . The current flows from the positive battery terminal and through the starter motor, which has some resistance R_s . Let's take a Kirchoff 'walk' around this circuit, starting from the battery and walking clockwise around the circuit.

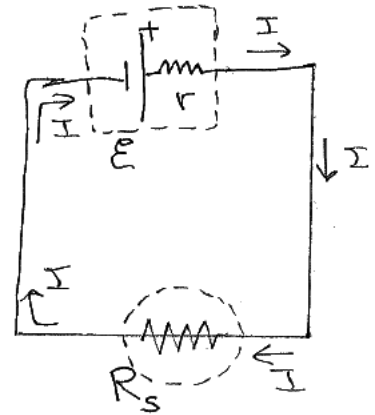

We gain $\Delta V = \xi$ volts crossing over the battery. Then the current I passing through the internal battery resistance r will represent a voltage drop of magnitude Ir in the direction the current is flowing. Our 'walk' is in the same direction the current is flowing, so we'll encounter a $\Delta V = -Ir$ when we step over this resistor.

Finally, we encounter the starter motor and we're walking in the same direction as the current is flowing, so we encounter a $\Delta V = -IR_s$ there.

Looking at all the voltage changes around this closed loop (which must add to zero) then: $\Sigma\Delta V = \xi - Ir - IR_s = 0$. Rearranging terms, we can write this as $\xi = I(r + R_s)$ or $I = \frac{\xi}{r + R_s}$.

Good Battery : the starter motor has a resistance of $R_s = 0.15 \Omega$ and a good car battery would have an EMF of $\xi = 12.5 \text{ volts}$ and an internal resistance of $r = 0.02 \Omega$. In this case, the current flowing through this circuit would be $I = \frac{\xi}{r + R_s} = \frac{12.5}{0.02 + 0.15} = 73.53 \text{ A}$.

The power that the starter motor will be using then is $P = I^2R = (73.53)^2(0.15) = 811 \text{ watts}$.

Bad Battery : a bad battery will deliver a lower voltage (emf) and may have a higher internal resistance so here let's assume $\xi = 10.0 \text{ volts}$ and $r = 0.2 \Omega$. In this case, the current flowing through this circuit would be $I = \frac{\xi}{r + R_s} = \frac{10}{0.1 + 0.15} = 40.0 \text{ A}$.

The power that the starter motor will be using then is $P = I^2R = (40.0)^2(0.15) = 240 \text{ watts}$.

Jump Start

To jump-start a 'dead' (or low) battery, we basically connect another battery in parallel with it: the positive terminal of the good battery being connected to the positive terminal of the bad battery, and similarly the negative terminal of the good battery connected to the negative terminal of the bad battery, as shown in the figure.

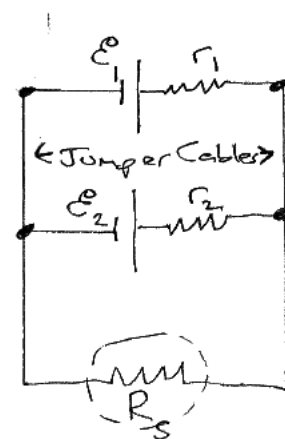

In the book version of this example, they also (realistically) add in some resistance in the jumper cables, but for this example let's ignore that and use the 'good' and 'bad' battery EMF's and internal resistances we used above.

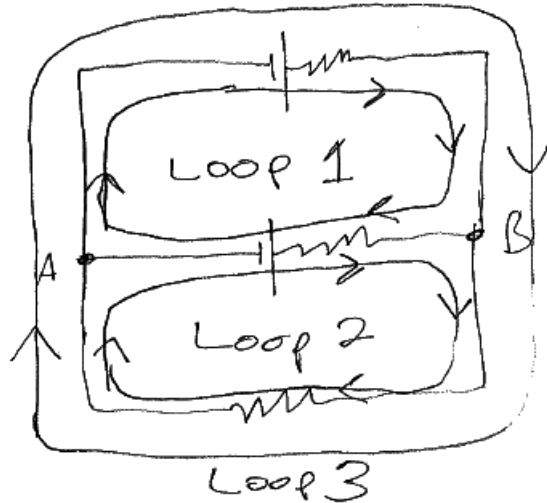
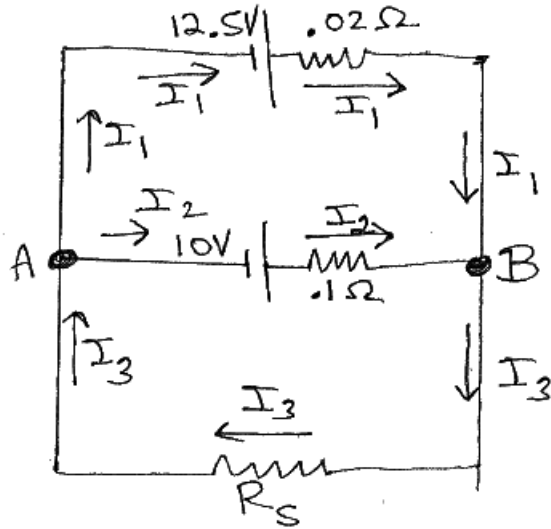

We have two nodes (junctions) here: places where two of more wires come together. Those represent spots where currents can split up or combine. I labelled them A and B in the figure.

Normally, current flows out from the positive side of the battery, so we'll add I_1 and I_2 currents associated with those points in the figure. From node to node, the current can't change, so we must have the same I_1 current from node A, then heading 'up', then to the right (through the good battery and it's internal resistance, and then 'down' the right side until it hits node B.

Similarly, we have the same I_2 current flowing from A to B through the bad battery and it's internal resistance.

Finally, at the nodes (junctions), we have some other current flowing from B down through the starter motor and back up to A.

Node/Junction rule : $\Sigma_{in} I = \Sigma_{out} I$

At node A then we have $I_3 = I_1 + I_2$ and at node B we have $I_1 + I_2 = I_3$. Those are actually the same equation, we only get one unique equation: $I_1 + I_2 = I_3$.

Loop Rule for upper loop : let's 'walk' around the closed loop that represents the upper half of this circuit. We'll start at point A and walk in a clockwise look around this loop. What voltage changes do we encounter?

- good battery: we're walking from the low side to the high side of this battery, so $\Delta V = +12.5 v$
- good battery's internal resistor: we're walking across this resistor in the same direction as (we think) the current is flowing, so the voltage will DROP: $\Delta V = -I_1 r_1 = -0.02 I_1$.
- bad battery's internal resistor: we're walking across this resistor in the OPPOSITE DIRECTION of the current there, which means we'll actually pick up voltage in the direction we're travelling: $\Delta V = +I_2 r_2 = +0.1 I_2$
- bad battery's emf: the voltage is higher on the positive side of the battery and here we're walking from the high to the low side, we our voltage change will be negative: $\Delta V = -10 volts$.

Summing the voltage changes around that loop: $+12.5 - 0.02I_1 + 0.1I_2 - 10 = 0$ or combining and collecting terms we can write this as $2.5 = 0.02I_1 - 0.1I_2$

Loop Rule for lower loop : let's 'walk' around the closed loop that represents the lower half of this circuit. We'll start at point A and walk in a clockwise look around this loop. What voltage changes do we encounter?

- bad battery: we're walking from the low side to the high side of this battery, so $\Delta V = +10.0 \text{ v}$
- bad battery's internal resistor: we're walking across this resistor in the same direction as (we think) the current is flowing, so the voltage will DROP: $\Delta V = -I_2r_2 = -0.10I_2$.
- starter motor: we're walking across this resistor in the same direction as the current there, so the voltage will drop: $\Delta V = -I_3r_s = -0.15I_3$

Summing the voltage changes around that loop: $+10 - 0.1I_2 - 0.15I_3 = 0$ or combining and collecting terms we can write this as $10 = 0.1I_2 + 0.15I_3$

Loop Rule for outer loop : let's 'walk' around the closed loop that represents the outer perimeter of the circuit, labelled as loop 3 in the figure, starting and ending at node A.

- good battery: we're walking across this battery from the low side to the high side, so pick up a $\Delta V = 12.5 \text{ v}$ at that point.
- now we step over the good battery's internal resistance and we're walking in the direction the current is flowing so the voltage will drop there: $\Delta V = -0.02I_1$
- the next element we encounter is the starter motor and we're walking across it in the direction the current is allegedly flowing, so $\Delta V = -0.15I_3$.

Summing the voltage changes around that loop: $+12.5 - 0.02I_1 - 0.15I_3 = 0$ which we can write as $12.5 = 0.02I_1 + 0.15I_3$

Solution : We now have FOUR equations (in the boxes above) but only three unknowns. If we just want to figure out how much power the starter motor has available to it now, we ultimately just need to know what I_3 is, so let's focus on equations that include that variable:

- $I_1 + I_2 = I_3$ (from either of the node rules)
- $10 = 0.1I_2 + 0.15I_3$ (from the lower loop)
- $12.5 = 0.02I_1 + 0.15I_3$ (from the outer loop)

Let's use the first equation to eliminate I_1 in the third equation. We can re-write the first equation as $I_1 = I_3 - I_2$ and substituting in that expression for I_1 in the third equation:

$12.5 = 0.02(I_3 - I_2) + 0.15I_3 = 0$ and after expanding this out and combining terms, we have $12.5 = 0.17I_3 - 0.02I_2$

This equation plus the 'lower loop' equation now give us 2 equations with 2 unknowns (I_2 and I_3)a
Ultimately, we find that $I_3 = 72.5 \text{ A}$, $I_2 = -8.75 \text{ A}$ and $I_1 = 81.25 \text{ A}$.

Note that I_2 came out negative, which means that current is actually flowing in the opposite direction we thought it would: some of the current flowing from the good battery is actually flowing INTO the bad battery (effectively charging it).

Also note that the current ultimately making it to the starter motor was 72.5 A which is actually a bit LESS than what the motor would be getting if connected solely to the good battery. The power delivered to the motor now is $P = I^2 R = (72.5)^2(0.15) = 788 \text{ W}$.

RC Circuit (A) - Charging : In the simple RC circuit shown, suppose the ideal battery has a voltage (EMF) of 12 V and it is in series with a $C = 1\mu\text{F}$ capacitor and an $R = 1000\ \Omega$ resistor. When we close the switch, find equations that describe the charge on the capacitor, the current flowing, and the power being dissipated by the resistor.

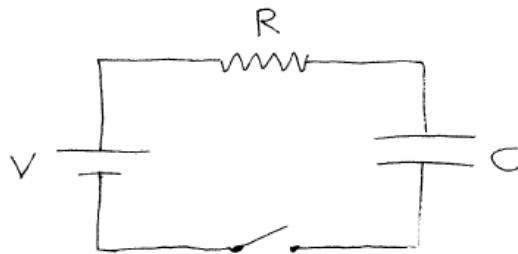

Once the switch is closed, our pretend positive charges will flow from the positive terminal of the battery, through the resistor, and build up on the top plate of the capacitor. This causes free charges in the bottom plate to leave that plate and migrate towards the negative terminal of the battery. Charge will continue to flow until all the connected elements in the top half of the figure are at the same potential, and all the connected elements in the bottom half of the figure are at the same potential. At that point, the current has dropped to zero, and the voltage across the capacitor will be 12 V .

Charge builds up on the capacitor according to: $Q(t) = Q_o(1 - e^{-t/RC})$ where Q_o is the steady state charge, once all the time variation has settled out. At that point no current is flowing, there's no longer a voltage drop across the resistor, so the capacitor has a voltage of 12 V across it. $Q_o = CV = (1 \times 10^{-6}\text{ F})(12\text{ V}) = 0.000012\text{ coul}$.

The time constant $\tau = RC = (1000)(1 \times 10^{-6}) = 0.001\text{ sec}$ so the capacitor is being charged up very quickly here.

Putting the parts together, $Q(t) = Q_o(1 - e^{-t/RC}) = (0.000012\text{ coul})(1 - e^{-t/0.001})$ or we could write that as $Q(t) = (0.000012\text{ coul})(1 - e^{-1000t})$.

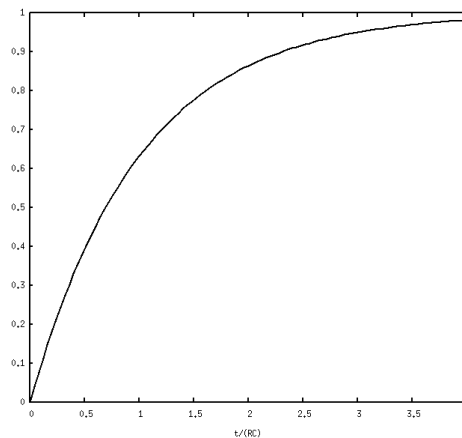

Plot of $Q(t)/Q_o$ with t in units of RC .

The current flowing will be $I(t) = dQ(t)/dt$. We could differentiate the equation we just found, or go back to the original symbolic version: $Q(t) = Q_o(1 - e^{-t/RC})$ so $dQ/dt = \frac{Q_o}{RC}e^{-t/RC}$ but $Q_o = CV$ so $I = \frac{V}{R}e^{-t/RC}$ (often written as $I = I_o e^{-t/RC}$) where V is the voltage from the battery so $I = \frac{12}{1000}e^{-1000t} = (0.012\text{ amp})e^{-1000t}$.

When we close the switch, an initial current of 0.012 amp flows, which then drops off exponentially (and very rapidly). One **millisecond** later, at $t = 0.001\text{ s}$ the current will have dropped to $I = (0.012\text{ amp})e^{-1} = 0.0044\text{ amp}$, for example.

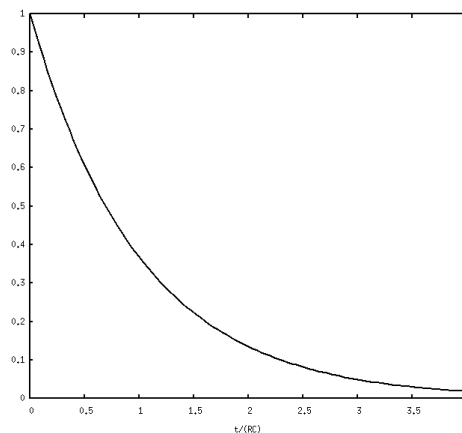

Plot of $I(t)/I_o$ with t in units of RC .

The power being dissipated by the resistor will be $P = I^2R = (0.144\text{ watts})e^{-2000t}$ so initially the resistor (maybe it's a little LED light bulb) puts out 0.144 watt but then drops off exponentially. At $t = 0.001\text{ s}$, it's only putting out $P = 0.0195\text{ watt}$.

RC Circuit (B) - Discharging :

Suppose we have a $C = 1\mu F$ capacitor that's been charged up with a 12 V battery as in the first example. Once the capacitor is fully charged, we disconnect the battery and then connect the capacitor to a lightbulb that has an internal resistance of $R = 0.5 \Omega$. Determine the current flow and the power emitted by the bulb as a function of time. How long does it take for the power output of the bulb to drop by half compared to its initial output?

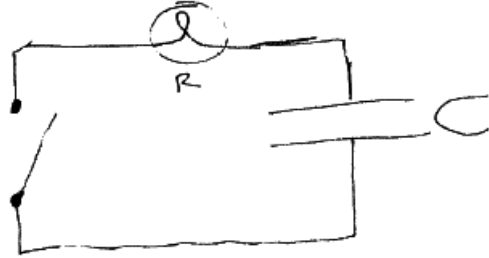

For a capacitor discharging through a resistor, the charge on the capacitor behaves as $Q = Q_o e^{-t/RC}$ and differentiating, the current behaves as $I = dQ/dt = -\frac{Q_o}{RC} e^{-t/RC}$. That's the rate at which charge is **leaving** the capacitor, flowing from its positive plate around the circuit towards its negative plate.

The initial charge on the capacitor will be $Q_o = CV$ where V is the voltage (emf) of the battery it was attached to. Making that substitution, we can write the current (magnitude) as $I = \frac{CV}{RC} e^{-t/RC} = \frac{V}{R} e^{-t/RC}$.

Here, the initial current $I_o = V/R = (12 \text{ volts})/(0.5 \Omega) = 24 \text{ amps}$. The time constant here will be $\tau = RC = (0.5)(1 \times 10^{-6}) = 5 \times 10^{-7} \text{ sec}$.

The current flow as a function of time then will be $I(t) = (24 \text{ amp})e^{-t/(5 \times 10^{-7})} = (24 \text{ amp})e^{-2000000t}$.

The power flowing through the bulb will be $P = I^2 R = (24)^2 (e^{-4000000t})(0.5) = (288 \text{ watts})e^{-4000000t}$.

At the instant the circuit is closed, the bulb starts emitting 288 watts (very bright). The brightness has dropped to half that when $144 = 288e^{-4000000t}$ or $0.5 = e^{-4000000t}$. Taking the natural log of each side: $-0.693147.. = -4000000t$ or $t = 1.73 \times 10^{-7} \text{ sec}$ or just $0.172 \mu\text{sec}$.

This is essentially a **flashbulb** in a camera, which emits a very brief bright flash, then dies down to almost nothing quickly. The very large initial power output (288 watts in this contrived example) is more than a little battery can produce, but is no problem at all for even a small capacitor.

If we leave things symbolic, $P = P_o e^{-2t/RC}$ so $P = \frac{1}{2}P_o$ when $0.5 = e^{-2t/RC}$ and taking the natural log and rearranging a bit, we find that the 'half-life' of the **power** will be $t_{1/2} = RC \frac{\ln(2)}{2} \approx 0.346RC$. With the values here, we found that the time constant $\tau = RC = 5 \times 10^{-7} \text{ sec}$ so the time for the **power** output to drop by half would be $(0.346)(5 \times 10^{-7} \text{ s}) = 0.173 \mu\text{sec}$.

RC Circuit (C) : In the circuit shown, both capacitors are initially charged to 45.0 V . (a) How long after closing the switch S will the potential across each capacitor be reduced to 10.0 V , and (b) what will be the current at that time?

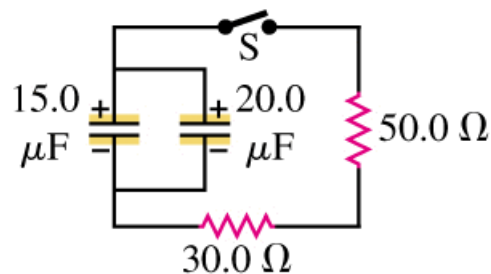

We can simplify this circuit first. The two capacitors in parallel can be replaced by a single equivalent capacitor using $C_{eq} = \Sigma C_i$ for parallel capacitors, so $C_{eq} = 35.0\mu F$.

The two resistors are in series, so we can replace those with a single equivalent resistor of $R_{eq} = \Sigma R_i$ for series resistors, so $R_{eq} = 80.0\Omega$.

In effect, we have a circuit with a single capacitor that's been charged up, in series with a single resistor. This is exactly the 'R-C' scenario covered in the chapter. The charge on the capacitor will decay according to $Q(t) = Q_o e^{-t/(RC)}$, with this charge flowing out into the circuit in the form of a current. The charge LEAVES the capacitor at a rate of $dQ/dt = -\frac{Q_o}{RC} e^{-t/(RC)}$, becoming a current flowing INTO the resistor of $I(t) = +\frac{Q_o}{RC} e^{-t/(RC)}$.

We'll need the time constant $\tau = RC$ to get numerical solutions for this problem, so let's go ahead and calculate it now: $\tau = (80.0)(35 \times 10^{-6}) = 0.00280\text{ s}$. (That's around 3 milliseconds, so clearly everything will happen pretty quickly here.)

Initially, the capacitors were charged up with a voltage of $V_o = 45.0V$. The charge and voltage on a capacitor are related by $C = Q/V$ so $V = Q/C$ which means we can write the VOLTAGE across the capacitor as $V(t) = Q(t)/C = \frac{Q_o}{C} e^{-t/(RC)}$. When the capacitors were originally charged up, though, from $C = Q/V$ we can write $Q = CV$ so initially $Q_o = CV_o$ and finally we can write the voltage across the capacitors as: $V(t) = V_o e^{-t/(RC)}$. That is, the voltage starts at the initial $45.0V$, and then decays away exponentially.

For part (a), we want to determine how long it takes for $V(t)$ to reach 10 volts so: $10 = 45e^{-t/(RC)}$ or $e^{-t/0.00280} = 10/45 = 0.22222$. Taking the natural log of both sides: $-t/0.00280 = \ln(0.22222...) = -1.5041$ from which $t = (-0.00280)(-1.5041) = +0.00421\text{ s}$ (or about 4 milliseconds).

To find the current flowing at this time, we determined that the current flowing could be written as $I(t) = +\frac{Q_o}{RC} e^{-t/(RC)}$ but $Q_o = CV_o$ so we can write this as $I(t) = \frac{V_o}{R} e^{-t/(RC)}$. We can just plug in the values we have and solve it: $V_o = 45$, $R = 80$, $RC = 0.00280$ and $t = 0.00421$, OR we can take a shortcut. We solved for this time by finding the value of t for which $e^{-t/(RC)}$ was equal to $10/45$ so we know the exact value of that exponential already. Thus $I = \frac{V_o}{R} \times \frac{10}{45}$ so $I = \frac{45}{80} \times \frac{10}{45}$ or $I = \frac{10}{80} = 0.125A$ exactly.